

## ET 20

### Tweeter

- Hi fidelity 20 mm soft dôme tweeter
- Hi efficiency magnet (N38 neodymium)
- HI quality special soft dôme material
- Ferrofluid for hi power handling

#### TECHNICAL SPECIFICATIONS

<b>Component</b>	Tweeter	
<b>Max power</b>	100 W	
<b>Nominal power</b>	10 W	
<b>Impedance</b>	3 Ω	
<b>Freq. Response</b>	2.5 KHz - 31 KHz	
<b>Sensitivity (2,83V/1m)</b>	90 dB	
<b>Magnet</b>	Neodymium	
<b>Magnet size Ø x h</b>	18 x 3 mm	0.709" x 0.118"
<b>Total driver displacement</b>	-	-
<b>Weight of one component</b>	0.045 kg	0.099 lb
<b>Voice coil Ø</b>	20 mm	0.787"
<b>Voice coil height</b>	1.5 mm	0.059"
<b>Dome</b>	Soft	



Unit : mm

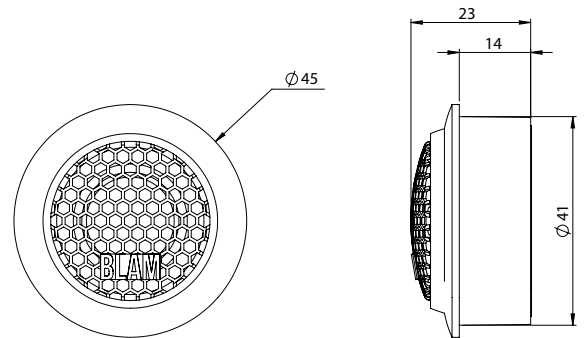

#### FREQUENCY RESPONSE / IMPEDANCE

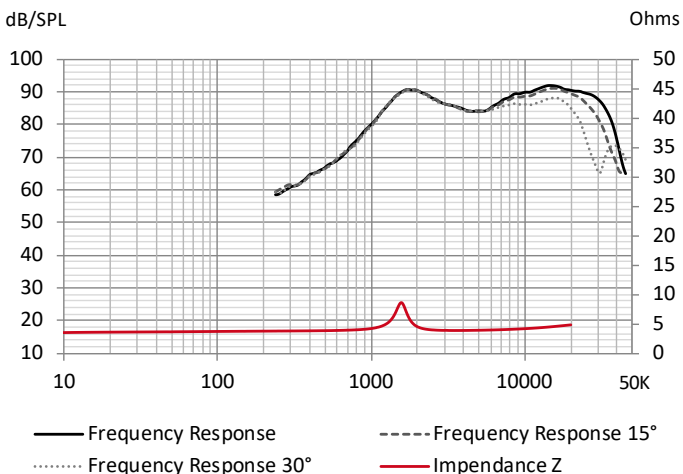

#### THIELE-SMALL PARAMETERS

<b>effective Ø (d)</b>	22 mm
<b>Sd</b>	3.80 cm <sup>2</sup>
<b>Xmax</b>	-
<b>Re</b>	3.52 Ω
<b>Fs</b>	1589 Hz
<b>Le</b>	-
<b>L2</b>	-
<b>Vas</b>	-
<b>Mms</b>	-
<b>Cms</b>	-
<b>BL</b>	-
<b>Qts</b>	-
<b>Qes</b>	-
<b>Qms</b>	-
<b>Sensitivity (dB/W/m)</b>	86.4 dB